



DESCRIPTIONS

Our 150W switching power supply is a AC to DC switching power transfer device which can provide a 12V, 12.5A max & 150W maximum DC output with constant voltage source. It comes with high efficiency, stability and almost all kinds of circuit protections, resulting in the long life time. When being input with full load, the maximum input current is 0.9A @ 220V and 1.8A @ 110V respectively.

When the output voltage reaches 150% of the rated voltage, the over voltage protection will works to shutdown and latch the output.

When the output current reaches 110 ~ 150% of the rated output current, the over current protection will works, and the modules will not enter into normal condition till the fault condition is removed.

Our switching power supply comes in a weight of 820g, and a size of 171mm(L) x 71mm(W) x 40mm(H), and a DC plug size of 5.5mm x 2.1mm x 12mm.

Our seitching power meets the UL, CUL, TUV/GS, CE, FCC, CB, PSE, CCC and the CEC Level IV requirement well.

The 3 views actual photos of the 150W switching power supply are shown as above.

FEATURES

- High Efficiency: 85%
- Input Voltage: 100VAC ~ 240VAC (specially 110/200VAC)
- Input Frequency: 47HZ ~ 63HZ
- Maximum Input Current: 1.8A @ 110V / 0.9A @ 220V
- Over Voltage Protection
- Over Current Protection
- Over temperature Protection
- Meet UL, CUL, TUV/GS, CE, FCC, CB, PSE, CCC
- Meet CEC Level IV requirement
- Long Life time

SPECIFICATIONS

Table 1. characteristics

Output Voltage(VDC)	Minimum Current(A)	Maximum Current(A)	Tolerance(%)	Regulation(VDC)
+ 12V	0	12.5	± 5	11.4 ~ 12.6



MECHANICAL DIMENSIONS

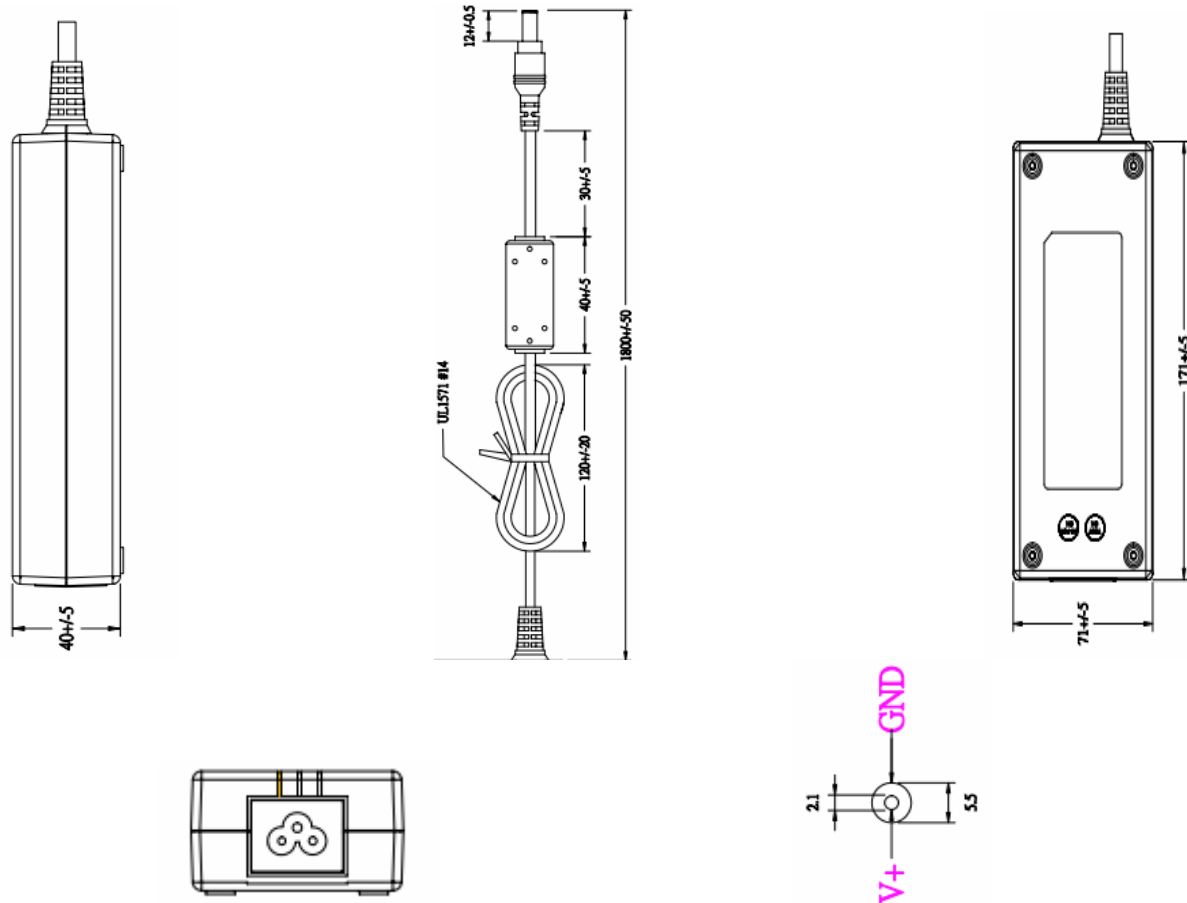

Figure 4. Mechanical Dimensions

NOTICE

1. ATI warrants performance of its products for one year to the specifications applicable at the time of sale, except for those being damaged by excessive abuse. Products found not meeting the specifications within one year from the date of sale can be exchanged free of charge.
2. ATI reserves the right to make changes to its products or to discontinue any product or service without notice, and advise customers to obtain the latest version of relevant information to verify, before placing orders, that information being relied on is current and complete.
3. All products are sold subject to the terms and conditions of sale supplied at the time of order acknowledgment, including those pertaining to warranty, patent infringement, and limitation of liability. Testing and other quality control techniques are utilized to the extent ATI deems necessary to support this warranty. Specific testing of all parameters of each device is not necessarily performed, except those mandated by government requirements.
4. Customers are responsible for their applications using ATI components. In order to minimize risks associated with the customers' applications, adequate design and operating safeguards must be provided by the customers to minimize inherent or procedural hazards. ATI assumes no liability for applications assistance or customer product design.
5. ATI does not warrant or represent that any license, either express or implied, is granted under any patent right, copyright, mask work right, or other intellectual property right of ATI covering or relating to any combination, machine, or process in which such products or services might be or are used. ATI's publication of information regarding any third party's products or services does not constitute ATI's approval, warranty or endorsement thereof.
6. IP (Intellectual Property) Ownership: ATI retains the ownership of full rights for special technologies and/or techniques embedded in its products, the designs for mechanics, optics, plus all modifications, improvements, and inventions made by ATI for its products and/or projects.