









Figure 1. Top View of AT6216



Figure 2. Bottom View of AT6216

Online Stores		Commission Fee	Unit Price (June 2024)	Buy Now
	shop.analogtechnologies Our own online store	Zero sale commission	\$0.70/100PCs	 *
	SMTZone Our own online store	Zero sale commission	\$0.70/100PCs	 *
	Digikey	≈47% sale commission	\$1.03/100PCs	 *

FEATURES

- The lowest frequency microphone in the world
- Small package
- Flat Frequency Response SNR of 65 Db
- Low Current
- MaxRF protection
- Ultra-Stable Performance
- Standard SMD Reflow
- Omni-directional

APPLICATIONS

- Mobile Telephones
- Smart Phones
- PDAs
- Digital Video Cameras
- Portable Media Devices with Audio Input

DESCRIPTION

The AT6856 is a high quality, low cost, low power analog output bottom-ported omni-directional MEMS microphone. AT6856 consists of a MEMS microphone element and an preamplifier. AT6856 has a high SNR and flat wideband frequency response, resulting in

natural sound with high intelligibility. Extra EMI filter for RF noise attenuation is built inside. Due to the built-in filter, AT6856 shows high immunity to EMI. The AT6856 is available in a thin 2.75mm × 1.85mm × 0.9mm surface-mount package. It is reflowing solder compatible with no sensitivity degradation. The AT6856 is Halogen and Lead free.

PIN CONFIGURATIONS

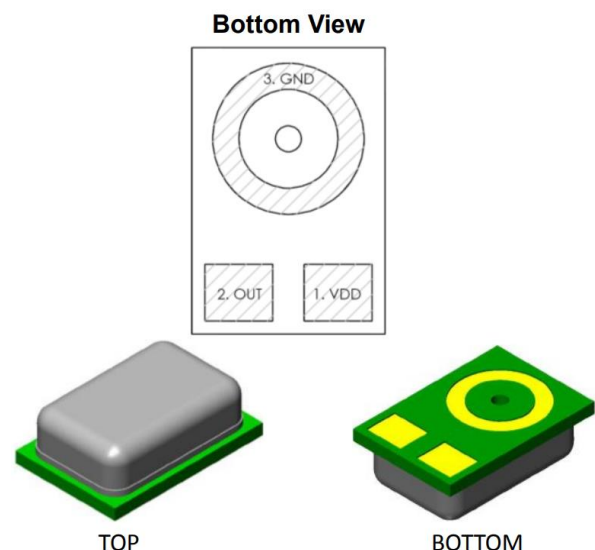

Figure 3. Pin Configurations

PIN DESCRIPTION

Table 1.

Pin	Symbol	Description
1	VDD	Power supply
2	OUT	Analog output signal
3	GND	Ground

ABSOLUTE MAXIMUM RATINGS

Table 2.

Parameter	Rating
VDD to Ground	-0.5V to +5V
OUT to Ground	-0.3V to V _{DD} +0.3V
Input Current to Any Pin	±5mA
Operating Temperature	-40°C to +125°C

CAUTION: Stresses above those listed in "Absolute

ELECTRICAL CHARACTERISTICS

(T_A = +15°C ~+25°C, V_{DD} = +1.8V, unless otherwise noted)

Table 3.

Parameter	Symbol	Test Conditions	Min.	Typ.	Max.	Unit
Power Supply Voltage ¹	V _{DD}		1.5		3.6	V
Power Supply Current ^{1, 2}	I _{DD}			120	150	μA
Sensitivity ¹	S	94dB SPL @1kHz	-39	-38	-37	dBV/Pa
Signal to Noise Ratio	SNR	94dB SPL @1kHz		65		dB(A)
Total Harmonic Distortion	THD	94dB SPL @1kHz		0.1	1	%
Acoustic Over load Point	AOP	10% THD @1kHz		130		dB SPL
Power Supply Rejection Ratio	PSRR	1kHz, 200mV _{p-p} sine wave on V _{DD}		70		dBV/FS
Power Supply Rejection	PSR	217Hz, 100mV _{p-p} square wave on V _{DD}		-99		dB FS(A)
DC Output		V _{DD} = 1.8V		0.7		V
Output Impedance	Z _{OUT}	@1kHz		100		
Directivity			Omni-directional			
Polarity		Increasing sound pressure	Increasing output pressure			

Maximum Ratings" may cause permanent damage to the device. This is a stress only rating and operation of the device at these or any other conditions above those indicated in the operational sections of this specification is not implied.



ESD CAUTION

This integrated circuit can be damaged by ESD. It is recommended that all integrated circuits be handled with proper precautions. Failure to observe proper handling and installation procedures can cause damage. ESD damage can range from subtle performance degradation to complete device failure.



Note:

1 100% tested

2 Maximum specifications are measured at maximum V_{DD} . Typical specifications are measured at $V_{DD} = 1.8V$.

BLOCK DIAGRAM

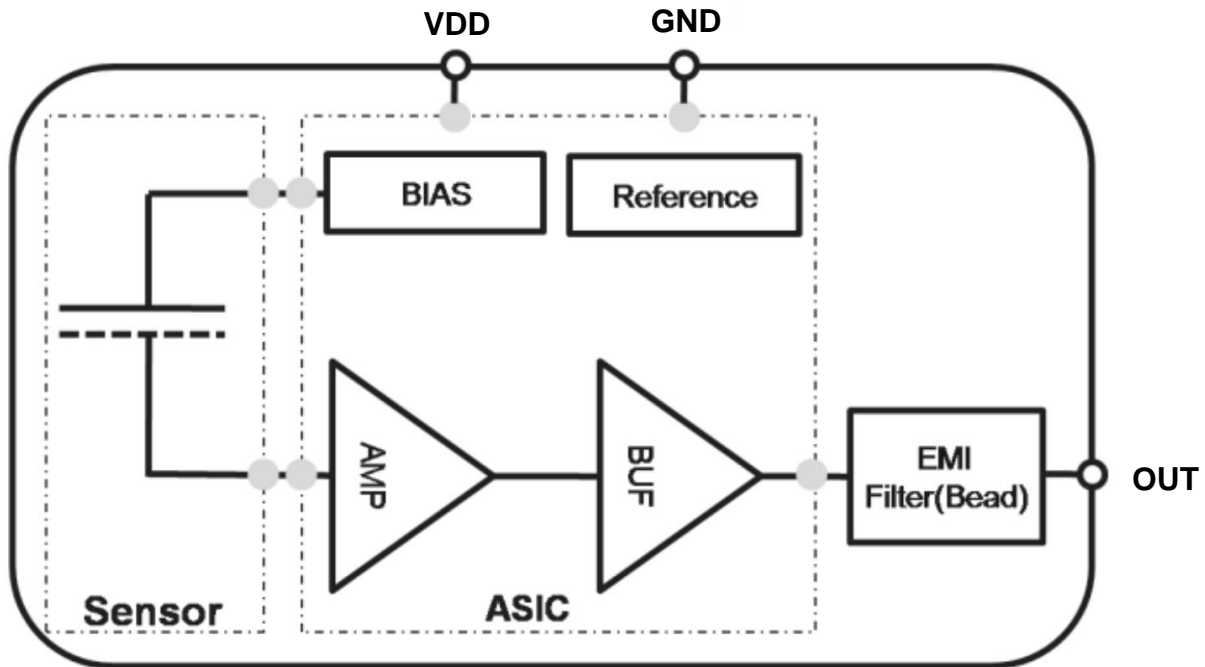

Figure 4. Block Diagram

TYPICAL CIRCUIT APPLICATION

The AT6856 output can be connected to a codec microphone input or to a high input impedance gain stage. A dc-blocking capacitor is required at the output of the microphone

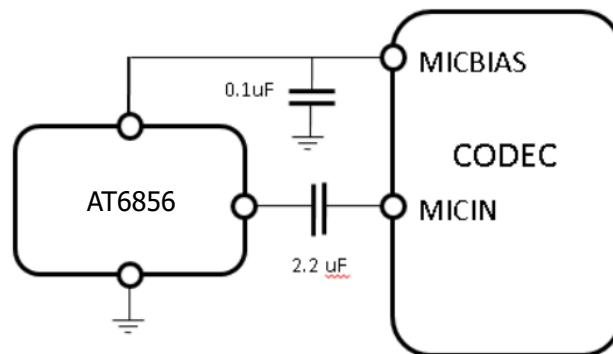

Figure 5. Connect to Audio OPAM

Note:

All Ground pins must be connected to ground.

Capacitors near the microphone should not contain Class 2 dielectrics.



TYPICAL CHARACTERISTICS

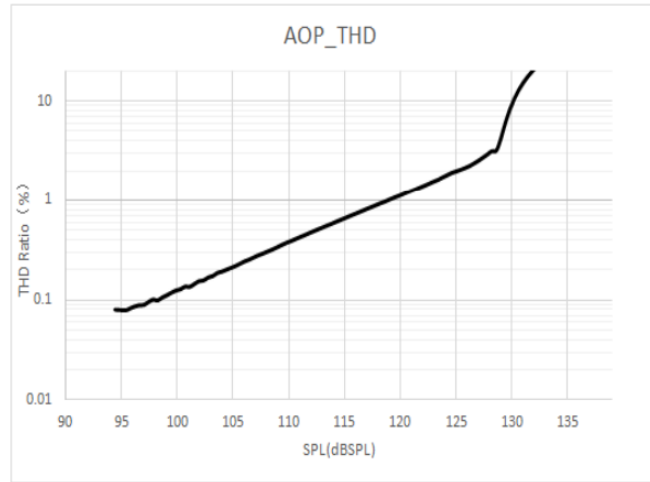
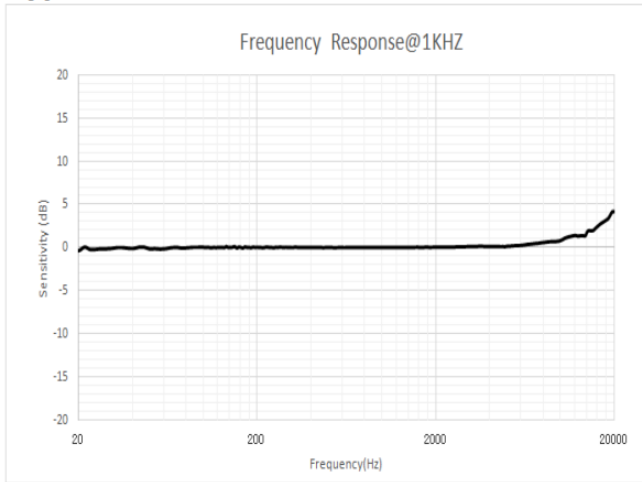

TYPICAL CHARACTERISTICS

The microphone sensitivity after stress must deviate by no more than ±3dB from the initial value.

1. Heat Test, Operational	Temperature: 125±3°C Duration: 1000 hours Voltage: Applied
2. Cold Test, Operational	Temperature: -40±3°C Duration: 1000 hours Voltage: Applied
3. Heat Test, Non-Operational	Temperature: 125±3°C Duration: 1000 hours Voltage: Not Applied
4. Cold Test, Non-Operational	Temperature: -40±3°C Duration: 1000 hours Voltage: Not Applied
5. Thermal Shock Test, Non-Operational	Temperature: -40±3°C and 125±3°C Duration: 30 minutes each, during 5 minutes ramp, 256 cycles Voltage: Not applied
6. Temperature humidity storage	Temperature: 85±3°C Humidity: 85±3%RH Duration: 1000 hours
	Temperature: 65±3°C Humidity: 95±3%RH Duration: 168 hours
7. Free Fall Test 1.5m	Placed inside test fixture and dropped on concrete from height 1.5m. 4 times by each surface and corner.
8. Vibration	4 cycles of 20 to 2000 Hz sinusoidal sweep with 20G peak acceleration lasting 12 minutes in X, Y, and Z directions.



9. Mechanical Shock	5 pulses of 10000g in each of the $\pm X$, $\pm Y$, and $\pm Z$ directions.
10. Electrostatic Discharge Test	Capacitance: 150pF Resistance: 330 Ω Duration: 10 times Air Discharge: Level 4 ($\pm 15kV$) Direct contact discharge: Level 4 ($\pm 8kV$)
11. Human Body Mode	± 2000 Volt
12. Charged-Device Model	± 250 Volt
13. Reflow	5 reflow cycles with peak temperature of 260°C
14. Solderability	245 $\pm 5^\circ C$, 5sec, 95% Tin on pad surface
15. Tumble test	300 tumbles from a height of 1m onto a steel base.
16. HAST	Temperature: 130 $\pm 3^\circ C$ Humidity: 85 $\pm 3\% RH$ Duration: 96 hours Voltage: Applied
17. Air Blow	0.45MPa, distance: 3cm, time: 10s

OUTLINE DIMENSIONS

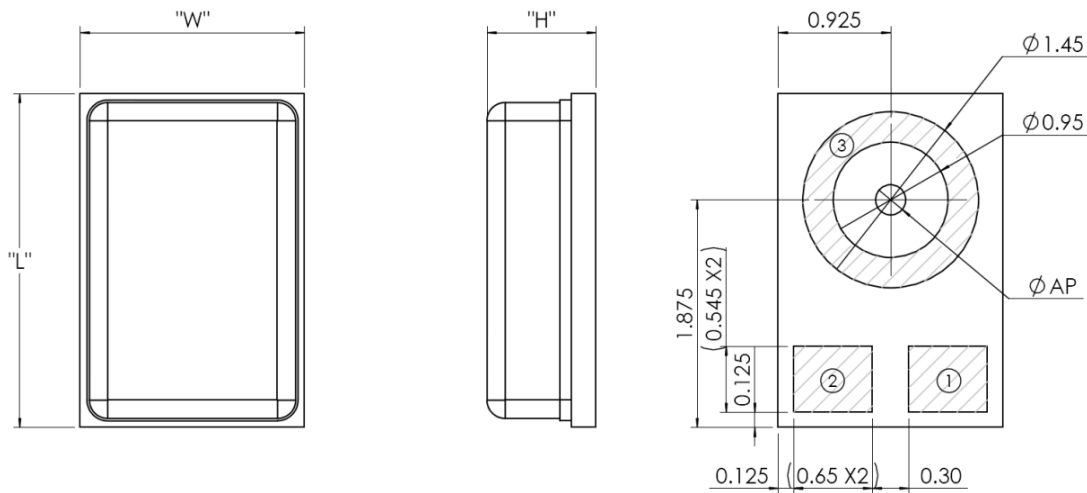

Figure 6. Outline Dimensions

Symbol	Dimensions		Tolerance	
	mm	inch	mm	inch
Length (L)	2.75	0.108	± 0.100	± 0.0039
Width (W)	1.85	0.073	± 0.100	± 0.0039
Height (H)	0.9	0.035	± 0.100	± 0.0039
Acoustic Port (AP)	$\varnothing 0.25$	$\varnothing 0.010$	± 0.050	± 0.0019

RECOMMENDED CUSTOMER LAND PATTERN

The recommended PCB land pattern for the AT6856 should have a 1:1 ratio to the solder pads on the microphone package. Care should be taken to avoid applying solder paste to the sound hole in PCB. The dimensions of suggested solder paste pattern refer to the land pattern which should be shrunk by 0.025 per side.

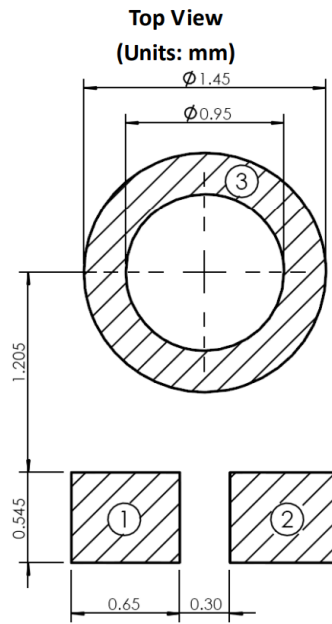
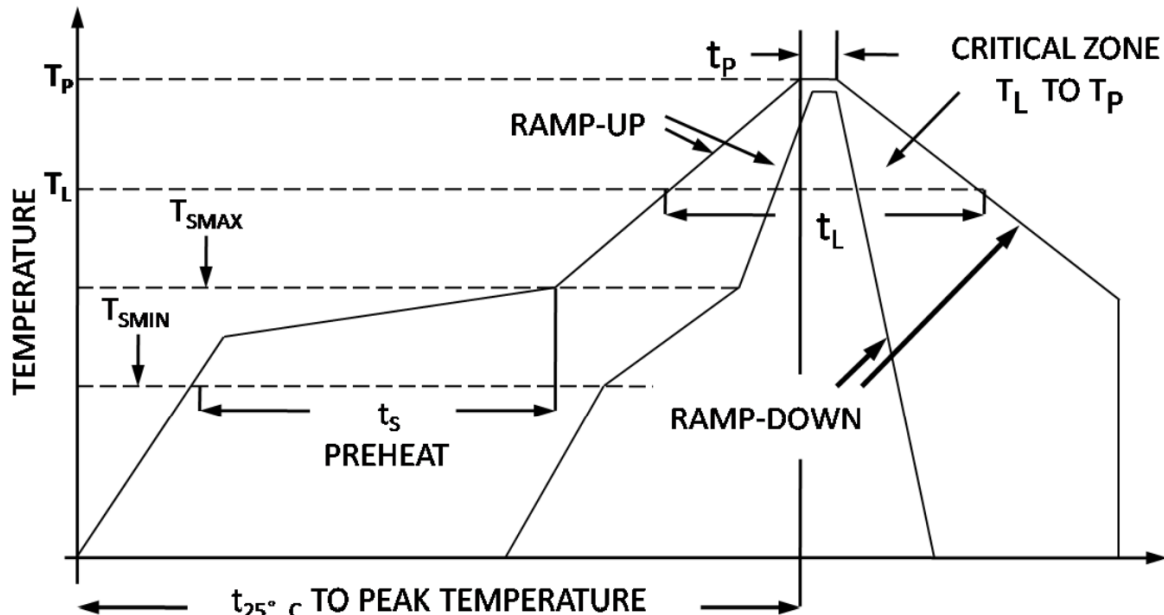

Figure 7. Recommended Land Pattern

SOLDER FLOW PROFILE

The reflow profile specified in this section describes expected maximum heat exposure of components during the reflow process of NMP product PWBs. Temperature is measured on top of component. All components have to tolerate at least this profile five times (5x) without affecting electrical performance, mechanical performance or reliability.







Pb-free and Sn63/Pb37 reflow profile requirements for soldering heat resistance:

Parameter		Reference	Pb-Free	Sn63/Pb37
Average Ramp Rate		T_L to T_P	1.25°C/sec max	1.25°C/sec max
Prehear	Minimum Temperature	T_{SMIN}	100°C	100°C
	Maximum Temperature	T_{SMAX}	200°C	150°C
	Time	T_{SMIN} to T_{SMAX}	60sec to 120sec	60sec to 120sec
Ramp-Up Rate		T_{SMAX} to T_L	1.25°C/sec	1.25°C/sec
Time Maintained Above Liquidous		t_L	60sec to 150sec	60sec to 150sec
Liquidous Temperature		T_L	217°C	183°C
Peak Temperature		T_P	260°C +0°C/-5°C	215°C ±3°C
Time within +5°C of Actual Peak Temperature		t_p	20 sec to 30 sec	20 sec to 30 sec
Ramp-Down Rate		T_{peak}	6°C/sec max	6°C/sec max
Time +25°C ($t_{25°C}$) to Peak Temperature			8 min max	6 min max

ORDERING INFORMATION

Part Number	Buy Now
AT6856	 *  *

NOTICE

1. It is important to carefully read and follow the warnings, cautions, and product-specific notes provided with electronic components. These instructions are designed to ensure the safe and proper use of the component and to prevent damage to the component or surrounding equipment. Failure to follow these instructions could result in malfunction or failure of the component, damage to surrounding equipment, or even injury or harm to individuals. Always take the necessary precautions and seek professional assistance if unsure about proper use or handling of electronic components.
2. Please note that the products and specifications described in this publication are subject to change without prior notice as we continuously improve our products. Therefore, we recommend checking the product descriptions and specifications before placing an order to ensure that they are still applicable. We also reserve the right to discontinue the production and delivery of certain products, which means that not all products named in this publication may always be available.
3. This means that while ATI may provide information about the typical requirements and applications of their products, they cannot guarantee that their products will be suitable for all customer applications. It is the



responsibility of the customer to evaluate whether an ATI product with the specified properties is appropriate for their particular application.

4. ATI warrants its products to perform according to specifications for one year from the date of sale, except when damaged due to excessive abuse. If a product fails to meet specifications within one year of the sale, it can be exchanged free of charge.
5. ATI reserves the right to make changes or discontinue products or services without notice. Customers are advised to obtain the latest information before placing orders.
6. All products are sold subject to terms and conditions of sale, including those pertaining to warranty, patent infringement, and limitation of liability. Customers are responsible for their applications using ATI products, and ATI assumes no liability for applications assistance or customer product design.
7. ATI does not grant any license, either express or implied, under any patent right, copyright, mask work right, or other intellectual property right of ATI.
8. ATI's publication of information regarding third-party products or services does not constitute approval, warranty, or endorsement.
9. ATI retains ownership of all rights for special technologies, techniques, and designs for its products and projects, as well as any modifications, improvements, and inventions made by ATI.
10. Despite operating the electronic modules as specified, malfunctions or failures may occur before the end of their usual service life due to the current state of technology. Therefore, it is crucial for customer applications that require a high level of operational safety, especially in accident prevention or life-saving systems where the malfunction or failure of electronic modules could pose a risk to human life or health, to ensure that suitable measures are taken. The customer should design their application or implement protective circuitry or redundancy to prevent injury or damage to third parties in the event of an electronic module malfunction or failure.